

# SENECT®

# FILTER|CONTROL

## Manual



FILTER



WATER  
LEVEL  
CONTROL



SENSOR  
CONTROL



TIME  
CONTROL



FEEDER



WLAN

## Product type

<b>Product name:</b>	SENECT® FILTER CONTROL
<b>Versions:</b>	FILTER CONTROL (150 W) FILTER CONTROL (300 W)
<b>Type:</b>	FC-A1-333-150 FC-A1-333-300
<b>Producer:</b>	SENECT GmbH & Co. KG An 44 – No. 11 76829 Landau / Germany

### **Important note:**

Please read this manual carefully and store it so that you can use it later. Read the warning and safety notes attentive.

Further information and latest software releases or documents can be downloaded from:

[www.senect.de](http://www.senect.de)





© SENECT GmbH & Co. KG - FW 00.80

---

## Table of contents

Product type.....	2
Table of contents.....	3
Used symbols and wording .....	4
General Security Notes.....	4
Intended use .....	5
General theory of operation .....	5
Getting started .....	6
Scope of delivery .....	6
Note.....	6
Installation and start-up.....	6
Operation .....	14
Display and symbols .....	14
Buttons and menu.....	15
Accessoires for the SENECT FILTER CONTROL.....	33
Connecting a solenoid valve to refill water .....	33
Troubleshooting: What if... ..	33
Technical Data .....	34
Information about the correct disposal .....	34
Guarantee .....	35

## Used symbols and wording

	<p><b>DANGER!</b> Warning of life threatening dangers.</p> <p><b>WARNING!</b> Warning of possible life threatening and / or severe irreversible injuries.</p> <p><b>ATTENTION!</b> Warning of possible medium or slight injury.</p>
	<p><b>ATTENTION!</b> Follow the notes to avoid damage of equipment.</p>
	<p><b>NOTE!</b> Further information for the use of the device.</p>
	<p><b>NOTE!</b> Further information for the use of the device.</p>

## General Security Notes

The SENECT® FILTER|CONTROL is an electronic control unit developed for controlling drum and belt filters.



Since it is an electric product the common prerequisites for a safe instrument usage must be fulfilled. The device must be operated with 230 V AC (~50 Hz). Ensure that all cables are installed safely so that no obstacles for persons are built and all.



Mount all cables and electric devices protected against direct environmental impacts like overheating by direct sunlight and water. Even if the product is protected against spray water, the product's lifetime will be elongated, if it is mounted on a protected place.

For many applications a ground fault circuit interrupter (interrupting current  $\leq 30$  mA) is required by law. Inform yourself about the valid legislation. If the mains plug cable is damaged, only the producer or a qualified person designated by the producer is allowed to repair the damage.

The operating temperature of the device must be between 0°C and +40°C. It is not allowed to modify the FILTER|CONTROL, to open the housing or to insert anything into the housing.

If the power cable is damaged, it must be replaced by the producer or a qualified person designated by the producer to avoid potential dangers.

The device is designed to be operated by professional users. It can be also operated by children over the age of 8 years and persons with limited physical, sensorial or cognitive ability, if they are supervised, trained in the operation of the device, able to operate the device safely and if they understand potential risks resulting from the operation. It is for children or persons with limited physical, sensorial or cognitive ability not allowed to perform any maintenance works.

Please store this manual. We suggest the storage a copy of the manual in the vicinity of the drum filter.

Technical and optical changes of this manual are subject to alterations.



**Warning:** Before doing any maintenance work switch off all electric devices or unplug the mains plug.

## Intended use



The SENECT® FILTER|CONTROL is an electronic control unit developed for controlling drum and belt filter in industrial applications. It can be combined with maximal two water level sensors (SENECT PS-300-MA or EPS-250-MA), one filter case switch, one solenoid valve (MVW-M12-SC) and one further actuator (e.g. alarm lamp VIS-LED).

On the three 230 V AC plugs, one spray pump, one UVC lamp or a 230 V AC filter motor and one circulation pump can be connected.



The direct control of drum or belt filters is only possible for filter with a 24 V DC filter motor with max. 5 A (FC-A1-333-150) or 10 A (FC-A1-333-300) or with a 230 V AC filter motor. The spray pump must be operated with 230 V AC with a maximal current of 8 A.

## General theory of operation

Drum and belt filter (terms were used interchangeably) remove suspended particles in aqueous solutions. Therefore, the water flows through a filter mesh and the particles stick to the mesh. The FILTER|CONTROL can detect if the filter mesh is clogged by measuring the water level in front of or behind the filter (only with the optional PS-300-MA or EPS-250-MA). If the

filter mesh is clogged, the FILTER|CONTROL starts the filter motor so that the drum starts to rotate or the belt starts to move and the spray pump will be activated. The filter mesh will be flushed and all dirt particles will be washed to the outlet.

Alternatively, if there is no water level sensor connected to the FILTER|CONTROL, a time controlled operation of the filter is also possible.

With the FILTER|CONTROL, many parameters can be set by the user so that many different types of filter can be operated with the FILTER|CONTROL.

With its 230 V AC circulation pump plug, one pump with a maximum power of 900 W can be connected and is therefore implemented in the control algorithm. This enables for example the emergency switch-off of this pump in case of water level below the alarming threshold. If you want to use a pump with a power of over 900 W, the optional Power Switch (PWS-24230-SC) can be used.

Besides the operation of the filter, the FILTER|CONTROL can regulate the water level (PS-300-MA or EPS-250-MA plus solenoid valve MVW-M12-SC necessary) by measuring the water level and activating a solenoid valve.

## Getting started

### Scope of delivery

- 1 x FILTER|CONTROL unit with 3 m power cable
- 1 x Motor cable
- 1 x Wall mount set
- 1 x Manual

### Note



Please check directly after delivery, that the package is not destroyed or damaged or was opened before. Please check also, that all parts as listed above are included. If anything is missing or broken, please contact us as soon as possible within 14 days.

Unfortunately, we cannot accept later information of damage, which happened during the transport.

### Installation and start-up



Choose a place for your FILTER|CONTROL which is clean, dry and protected from direct sunlight. Ensure that all cables are placed safely and all regulations are fulfilled.

To mount the FILTER|CONTROL, place the delivered wall mounting parts on the back of the device. Tight the parts with the delivered screws (3 x 10 mm, see Fig. 1). Afterwards, you can use the wall mounting parts of the FILTER|CONTROL to attach the device to its place, e.g. on a wall.

## Open channel filter (gravity mode)

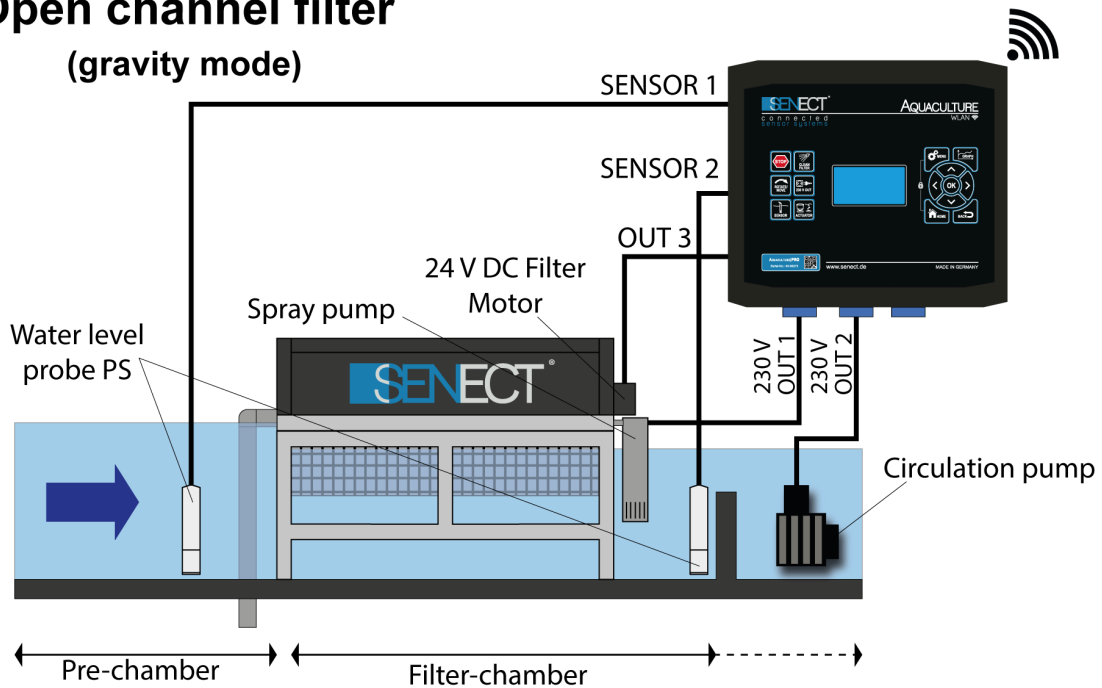

## Boxed filter (pipe connections, gravity mode)

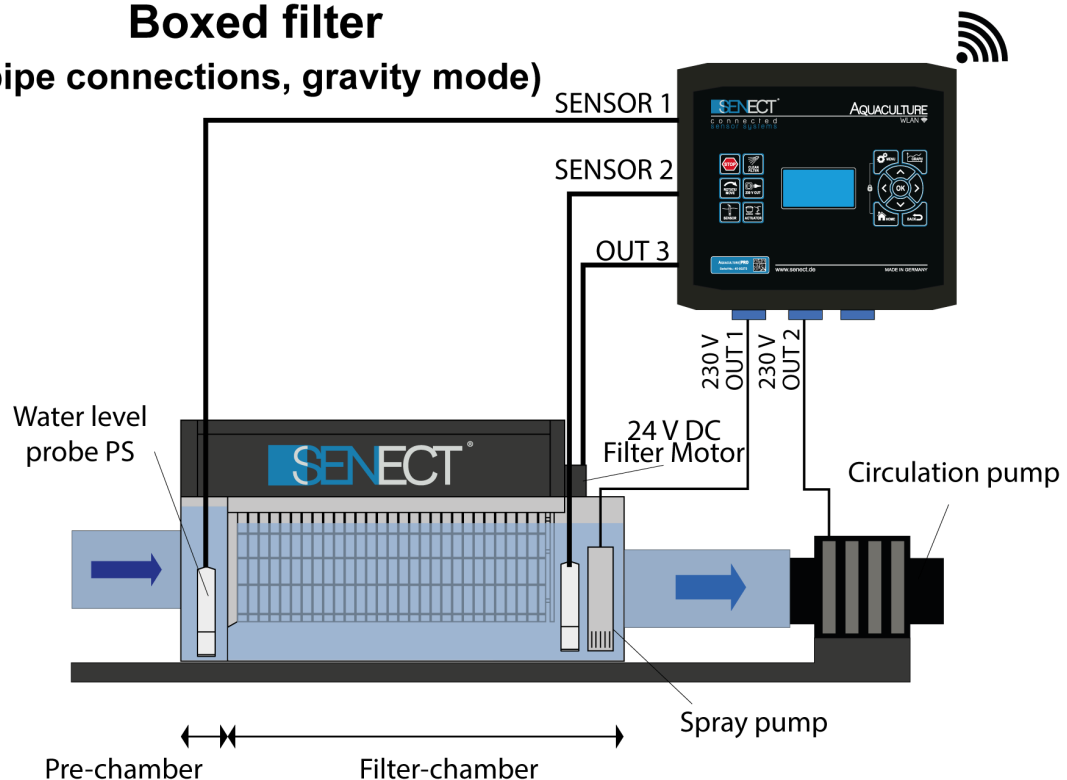

**Fig. 1:** Connecting an open channel drum filter and a boxed drum filter. Please note that the filter motors here are controlled by the high-power actuator output port OUT 3.

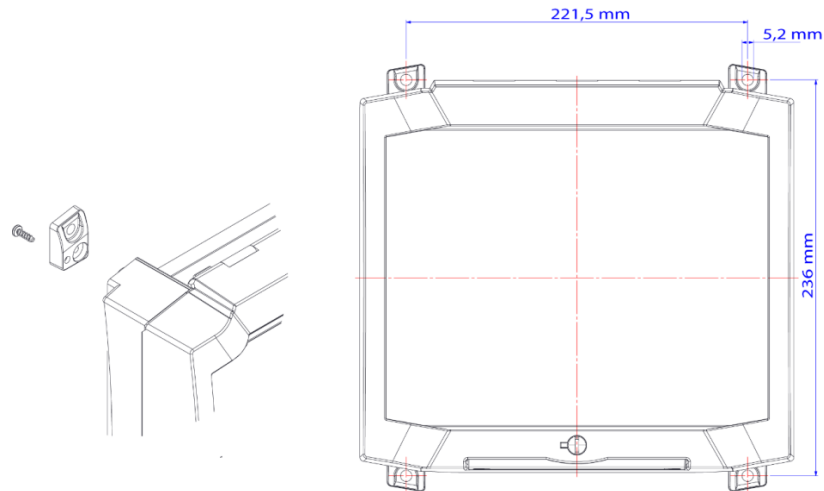

Fig. 1: Wall mounting parts and dimensions of the drill holes of the FILTER|CONTROL.

Plug the 230 V power plug of the FILTER|CONTROL in a spray water protected plug (IPx4 or higher) but do not switch FILTER|CONTROL on yet.

### 1.) Water level sensor installation

If you do not have a water level sensor, please continue with 2.).



The optimal location of the water level sensor (PS-300-MA or EPS-250-MA) is where a control over the proper functioning of the circulation pump is. In a **gravity system**, this location is usually behind the filter while in **pumped systems**, this is typically before the filter or in the pre-chamber of the filter.

Please do not insert the water level sensor deeper than 2.5 m and ensure that it is well fixed and at a place with low direct currents. Read also the instructions of the level sensor manual.

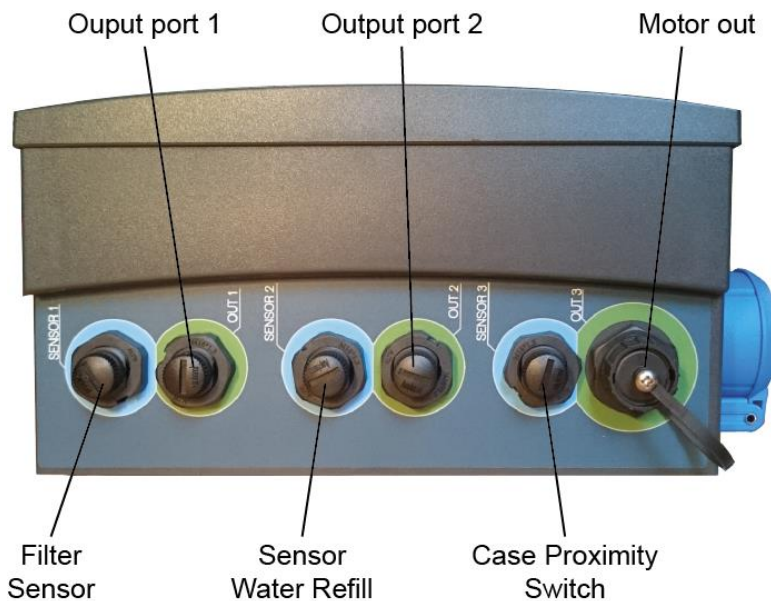

Fig. 2: Sensor and actuator ports of the FILTER|CONTROL.

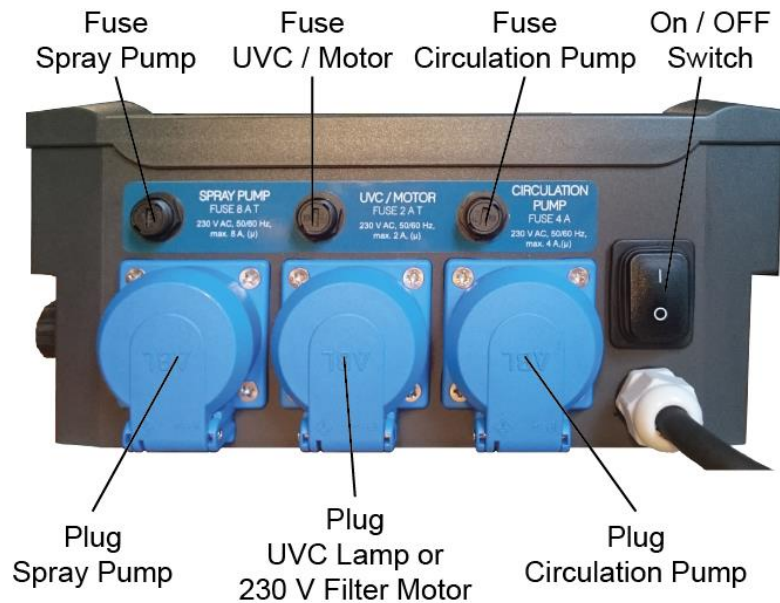

Fig. 3: View at the lower side of the FILTER|CONTROL.

Connect the water level probe PS for the filter control with **SENSOR 1** (see Fig. 2). If you are using a second water level probe PS, connect the 2<sup>nd</sup> probe with **SENSOR 2**.

If you are using two water level sensors EPS-250-MA, connect the sensor in the filter chamber with **SENSOR 1** and the sensor in the pre chamber with **SENSOR 2** (for water refill).

## 2.) Case switch

If your filter is equipped with a case or cover proximity switch, you can connect it to **SENSOR 3**. If you do not have a suitable plug at your switch, you can order the proper plug from SENECT or your dealer.

The function of the case switch is to switch off the drum motor and a connected UVC lamp (which are often located inside the drum filter), when the cover is opened (mode: drum filter). In the mode "belt filter" is selected, then only the UVC lamp is switched off.

Please consider that the case or cover switch does not fulfil all requirements to be an emergency stop switch according to EN ISO 13850:2015-10.

## 3.) Filter motor

### 24 V DC Filter motors:

Ensure that the filter motor is correctly installed at your filter and check in the technical documentation, if the motor can be operated with 24 V DC (max. current 5 or 10 A). If yes, you can connect the motor with the delivered cable (polarity: red = +, black = -). Connect the motor cable plug to **OUT 3** (motor).

**230 V AC Filter motors:**

If your filter is equipped with a 230 V AC motor, connect its plug at the 230 V plug **UVC / MOTOR**. Please consider that only motors with a power of max. 500 W can be connected directly. Motors with a higher power consumption can be connected via the optional Power Switch 24-230.

Note here, that all functions where the motor speed is controlled by the FILTER|CONTROL do not work, because there is just an on / off switching of the filter motor possible. These functions are:

- Intensive cleaning programme
- Soft motor start
- High-pressure cleaning mode

If you want to use these functions with AC motors, you need a variable frequency drive to control the motor speed.

**230 V / 400 V AC Filter motors connected via variable frequency drive (VFD):**

For changing the rotation speed of AC filter motors, which allows to use all functions which change the motor speed, a variable frequency drive between the FILTER|CONTROL and the filter motor is necessary.

SENECT offers fully configured, parametrized and wired VFDs. The green labelled actuator cable from the VFD must be connected to one the actuator output ports, e.g. OUT 1.

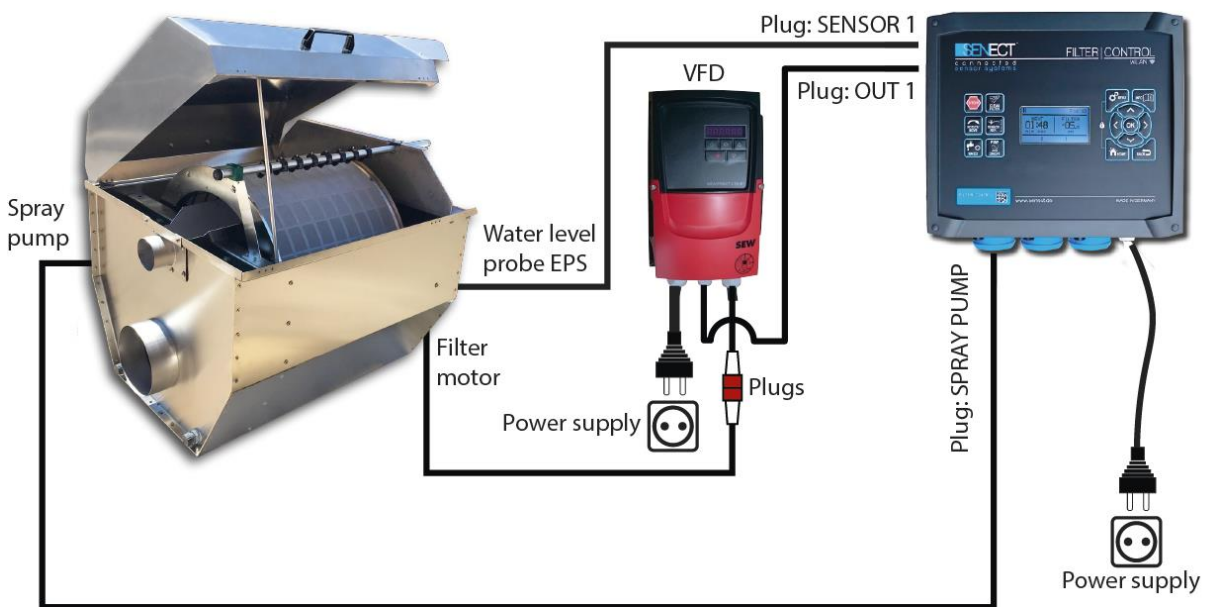

**Note:** Select the function “filter motor” for the corresponding actuator output port (here OUT 1) and select the additional function “variable frequency drive”.

#### 4.) Connecting the spray and circulation pump

If the pumps are correctly installed, arrange all cables safely to your FILTER|CONTROL. Check on the data sheets of your pumps, if they fit to the specifications of the FILTER|CONTROL (spray pump: 230 V AC, max. 1800 W, circulation pump: 230 V AC, max. 900 W). Plug the spray pump connector into the plug „**SPRAY PUMP**“ and the connector of the circulation pump to the plug „**CIRULATION PUMP**“ (see Fig. 3).



To operate a drum or beltfilter correctly, it is necessary to connect the filter motor and spray pump according to the specifications of the filter producer.



**Every drum or belt filter consumes water. Therefore, it is absolutely necessary that the lost water is refilled. Ensure that either the water is replenished automatically or if manually, that the water level in your tanks or ponds is constant.**

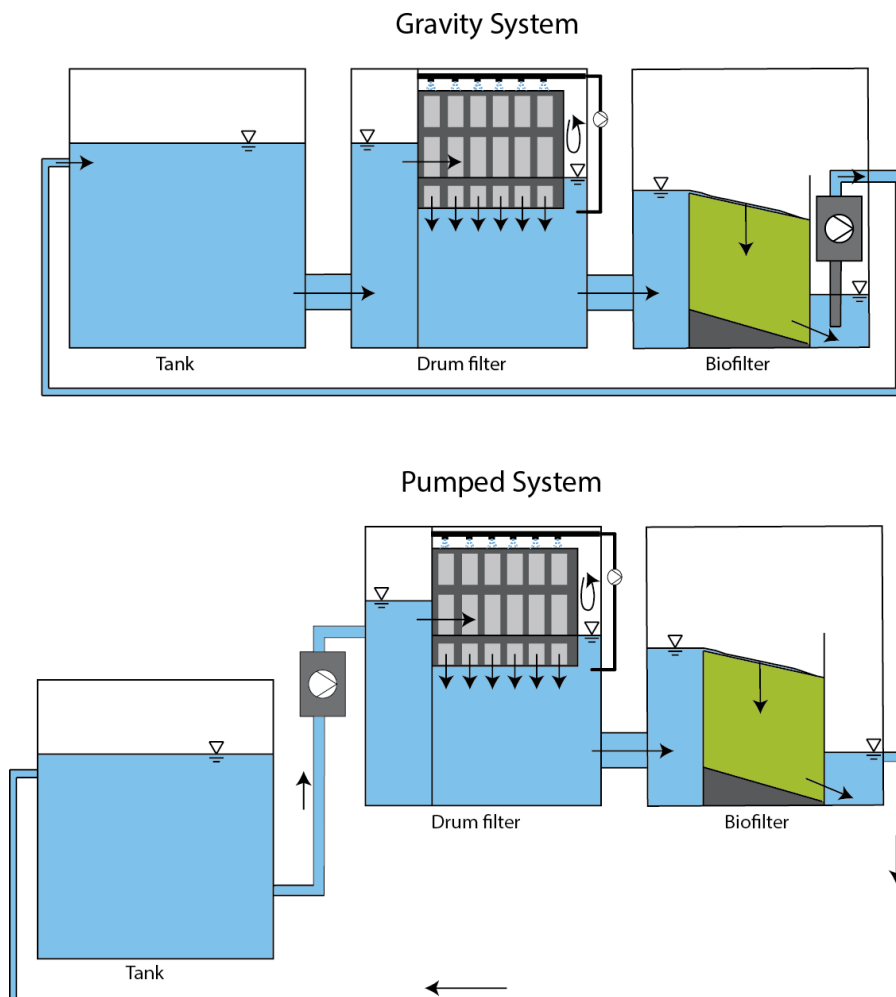

**Fig. 4:** Sketch showing the general two hydraulic systems in which drum filter are operated.

## **STARTING THE SYSTEM**

Switch the FILTER|CONTROL on with the **ON/OFF Switch** at the bottom (Fig. 3).



**Note:** Changing languages can be easily done in the menu. Press the button MENU and select under „System Einstellungen / Sprache“ the language „English“.

By pressing the button **MENU**, you can configure all necessary settings. With the cursor buttons **↑** and **↓**, you can choose the desired menu item and to confirm your selection, press **OK**. The button **BACK** brings you always one hierarchical level down, while **HOME** displays the normal screen and exits the menu.

If your filter is used in a pumped system, select in the **Filter Settings** as **Filter Mode „Pumped System“**. If you are operating the filter in gravity mode, select **“Gravity System”**.

If you are using a 230 V AC filter motor select in the menu at **230 V Plug / 230 V Plu 2** the function **„Filter Motor”**. If you are using a 230 V AC filter motor connected via a variable frequency drive to an actuator output port, select in the menu at **Output ports / Plug 1** the function **„Filter Motor”** and the additional function **“Var. Frequency Dri”**.

Select the proper type of water level sensor connected to your FILTER|CONTROL. If you are using the water level probe PS, select **Sensors / Sensor backwashing / Sensor Type** the type: **„PS-300-MA”** while if you use the water level sensor EPS, select **„EPS-250-MA”**.

Switch on your circulation pump by pressing the button **„PUMP ON/OFF”**. You can now also switch off (and on) the filter operation (incl. circulation pump) by pressing the button **„STOP”**.

Clean the filter by pressing the button **„CLEAN FILTER”**. After the cleaning process, check the water level in your system. If the water level is correct, you have to set the water level sensor(s) to zero (referencing). Press the button **„SENSOR REF.”** and confirm with yes.

Now, your system is ready for operation.

To achieve the most efficient operation, you have to set all settings so that they fit to your filter, for example the cleaning duration, etc. You'll find more information in the chapter **“Operation”**.

## **Getting started – Short version**

1. Mount the FILTER|CONTROL at a protected place.
2. Mount the water level sensor PS submerged in the filter chamber (gravity system) or in the pre chamber (pumped system).

3. Connect the filter motor cable, the spray pump, the water level sensor, the cover switch and the circulation pump with your FILTER|CONTROL.
  - a. If you are using a VFD, connect the motor to the VFD, connect the green marked actuator cable of the VFD to the FILTER|CONTROL to OUT 1 and plug the VFD power plug into a power supply mains plug.
4. Switch the FILTER|CONTROL on.
  - a. If you are using a VFD, select in the **MENU** the function “filter motor” for the corresponding actuator **output port** (e.g. Plug 1) and the **additional function** “variable frequency drive”.
5. Set the correct backwash settings in the **MENU** under **Filter Settings**.
6. Switch on the circulation pump (button **PUMP ON/OFF**) and clean the filter (button **CLEAN FILTER**).
7. Check the water level. If the water level is correct, set with the button **SENSOR REF** the water level to zero.

Now, your system is ready for operation.



Please note that the filter backwash water levels refer to the **referenced** water level while the alarm settings of the sensor refer to the **absolute** water level.

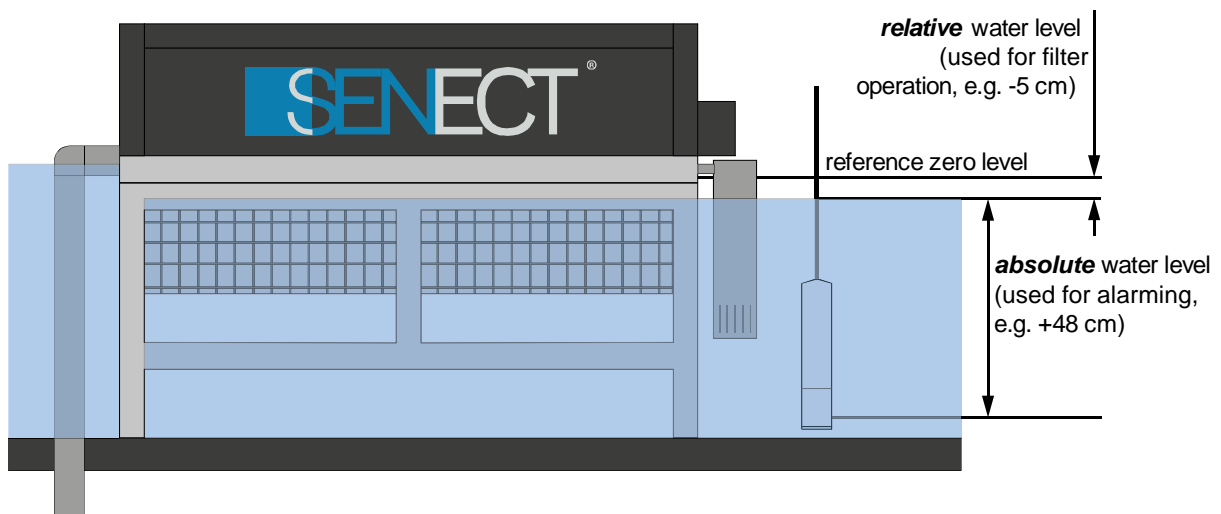

Fig. 2: Relative water level vs. absolute water level.

## Operation

### Display and symbols

On the display, you'll find information about current measurement and the status of the instrument.

The upper row shows you action symbols, which display the current running actions or modes of operation.

The action symbols are:

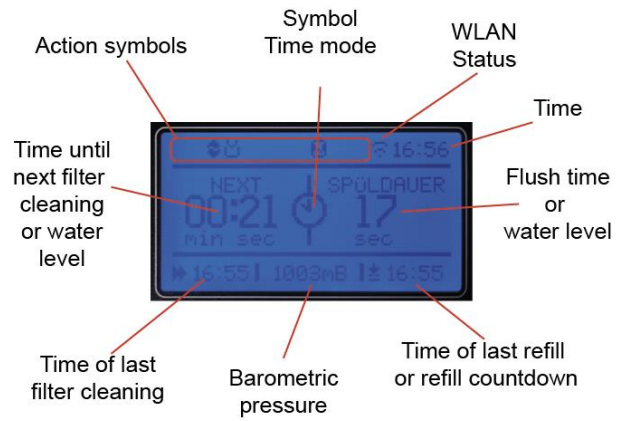
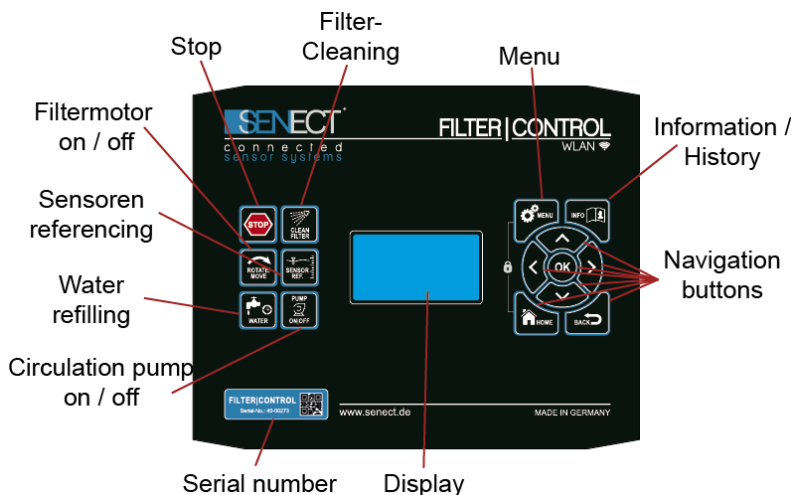

**Fig. 5:** The display of the FILTER|CONTROL.

!	Alarm active
	Pause, release with "STOP"
🔒	Pin code active, unit blocked
⚙️	Circulation pump on
🧼	Filter cleaning
🚰	Water refill
.	WLAN: Not connected
—	WLAN connected, but not internet access
📶	WLAN: Connected with network
⚙️	WLAN: Configuration mode active
🔄	WLAN: Update available

### Buttons and menu

The FILTER|CONTROL is operated by the user via the buttons on the front. With the navigation buttons (↓, ↑, ←, →, **BACK** and **HOME**) you can navigate through the menu and change the displayed view (e.g. showing the water level or the barometric pressure).



**Fig. 6:** Buttons of the FILTER|CONTROL.

**Cursors:** With the cursor buttons you can move through the menu and change settings..

**OK:** With OK you confirm your selection.

**BACK:** The button BACK brings you one level back in the menu.

**HOME:** By pressing home, the home screen will be displayed and you exit the menu.

**MENU:** The menu is opened by pressing MENU.

**INFO:** The button INFO shows you information about the filter operation like the history of actions.

**Lock:** By pressing the buttons **MENU** and **HOME** simultaneously, the lock is active. To unlock the keypad, you have to enter the Pin Code. The Pin Code is 0000 unless you have changed it in the menu.

**STOP:** By pressing **STOP** all actions are stopped immediately and the device is in the break mode. By pressing **STOP** again, the device starts again.

**CLEAN FILTER:** By pressing **CLEAN FILTER** you start a cleaning process. If you press longer than 3 s, the intensive cleaning mode is started.

**ROTATE/MOVE:** To move the belt or rotate the drum manually, press ROTATE/MOVE. If you release the button, the motor stops.

**SENSOR REF:** To reference the water level sensors, press SENSOR REF. If you confirm then with ok, the water level is set to 0.

**WATER:** If there is a SENECT solenoid valve connected, pressing WATER leads you directly to the water refill menu. If you press WATER longer than 3 s, the solenoid valve is opened until you release the button.

**PUMP ON/OFF:** With the button PUMP you can switch the circulation pump on and off.

All settings and parameters can be set in the menu. The following overview shows the menu exemplarily. Please consider that some parts of the menu are dynamic, which means that they only appear in certain constellation or with certain equipment.

**Table 1:** Description of the history entries.

<b>Entry</b>	<b>Description</b>
System Start	Start of the control unit
Man. Backwash	Backwashing started manually (by pressing the button)
Sens. Backwash	Backwashing started by sensor measurements
Sens. Forced B.	Forced backwashing started by sensor
Time contr. Bw.	Time-controlled backwashing
Abort backwash	Manual interruption of backwashing
Modus changed	Operating mode of filter settings changed (automatic vs. time-contr.)
Intensive cleaning	Intensive backwash
Drive error 1	Error on high-power OUT 3: no current measureable
Drive error 2	Error on high-power OUT 3: overload
Drive error 3	Error on high-power OUT 3: short circuit
Break active	Break mode is active (e.g. by pressing STOP)
Break deact.	Break mode was deactivated
Dry run prot.	Dry run protection mode was started
Reset dry run.	Dry run protection mode was manually stopped
Man. Pump off	Pump was switched off manually
Man. Pump on	Pump was switched on manually
Power fail	Power failure or control unit switched off
Factory setting	Factory settings loaded
Man. Refill.	Water refill was started manually
End of refill	End of water refilling
Timer refill	Start of time-controlled refilling
Sensor refill	Start of sensor-controlled refilling (time table)
Interv. refill	Start of time-controlled refilling (interval)
Abort sensorc.	Abort of sensor-controlled water refill (exceeding max. time)
Timer on	Timer controlled output was switched on
Timer off	Timer controlled output was switched off
Sen.Reg.on	Sensor controlled output was switched on
Sen.Reg.off	Sensor controlled output was switched off
Feeding	Feeder active
No Feeding	Feeding cancelled due to environmental parameters e.g. O <sub>2</sub> , temp.
Cover opened	Cover switch recognizes open cover
Cover closed	Cover switch detects closing of cover
Output Alarm	Alarm on output
Output Ok	Alarm on output cleared
Sensor Error	Error at sensor
Sensor Alarm	Sensor measurements above or below alarm thresholds
Sensor Ok	Sensor values again in normal range

# Filter Menu

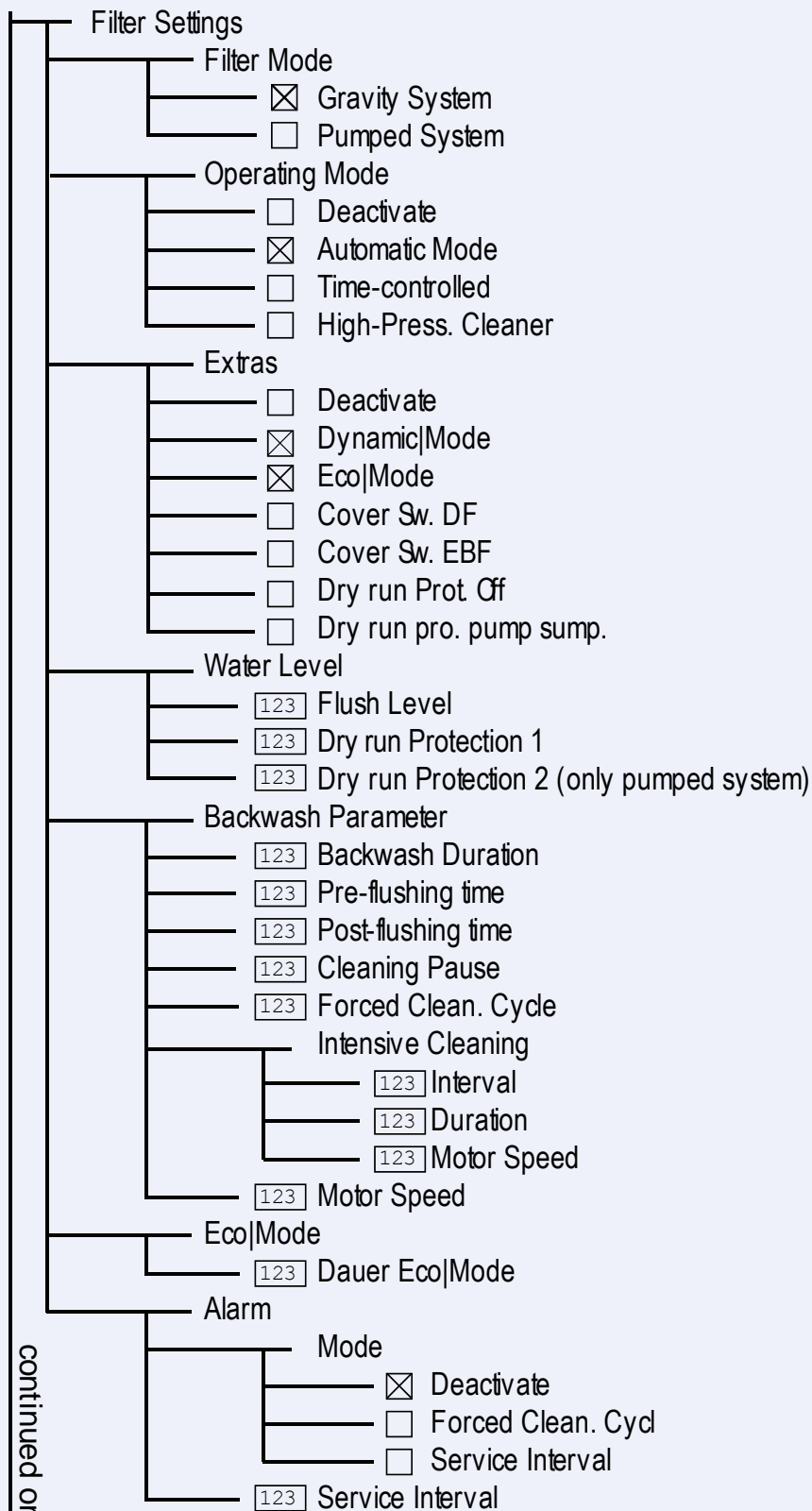

continued on next page

<u>Input value:</u>	<u>Selection:</u>
<input type="text" value="123"/> Numerical	<input checked="" type="checkbox"/> selected (factory settings)
	<input type="checkbox"/> not selected

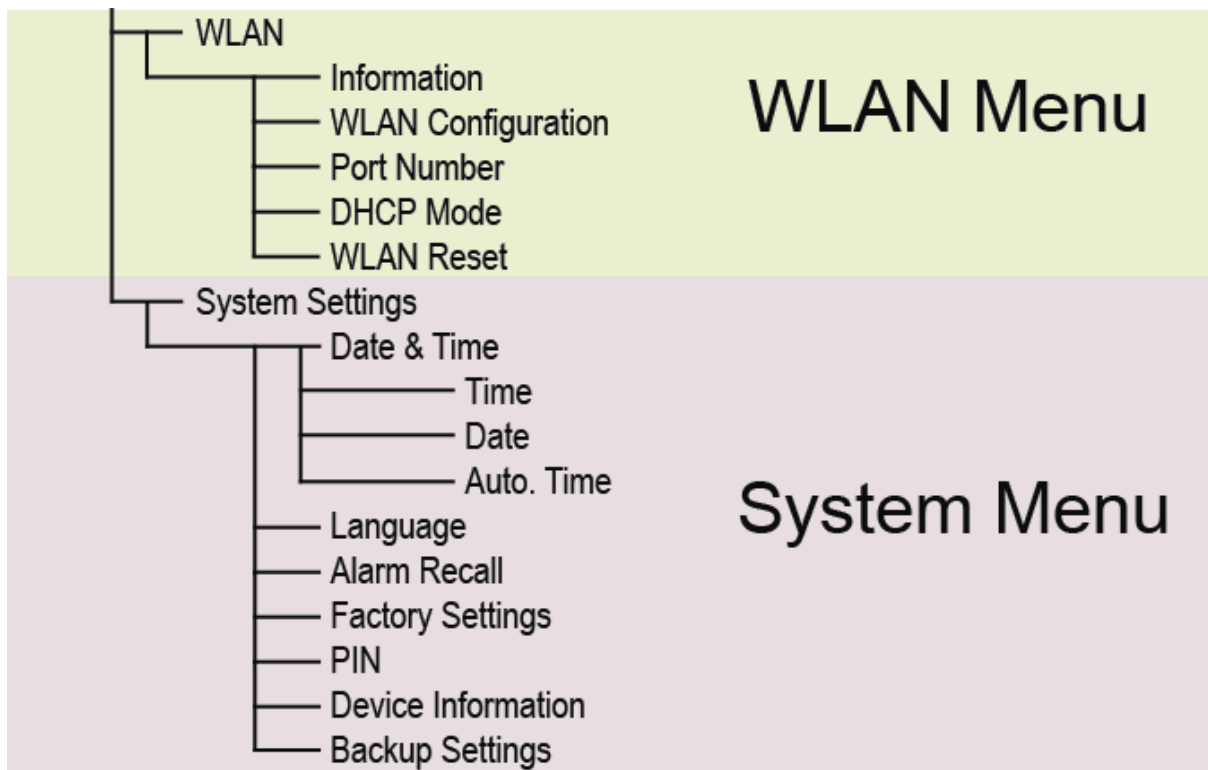

## Filter settings

Here you can configure all relevant settings for the filter operation.

- **Filter Mode**

Select here, if you are using your filter in a gravity or pumped system. The selection here means that the filters backwashing is triggered by an decrease of the water level (typically for gravity mode, where the sensor is installed behind the filter) or by an increase (when the sensor is installed before the filter).

- **Operating Mode**

Without a water level sensor, the filter is operated time-controlled. In this menu point, you can choose the operation mode. „**Automatic mode**“ means that based on the clogging of the filter mesh, indicated by the measurements of the water level sensor, the cleaning is initiated. In the „**Time-controlled mode**“, the filter is cleaned in regular time intervals. The „**High-Press. Cleaner**“ mode lets the filter motor run continuously, but slow without activating the spray pump. This mode is handy, when the filter mesh is cleaned manually with a high-pressure cleaner.

- **Extras**

Here you can select the activation of extra functions.

- 1. Dynamic|Mode:**

The Dynamic|Mode is a special algorithm which leads to a more stable clogging-induced control of the backwashing. With this mode, the backwash water level is continuously corrected for changes in the water level. Please note, that the backwashing is then not at exactly the specified backwash water level. Instead it starts when the “corrected” backwash level is reached.

- 2. Eco|Mode**

With the Eco-Mode you can decrease the water consumption of your filter. When the water level sensor initiates the cleaning, only the filter motor is activated for a short time to bring the until then unused filter mesh into the water. By monitoring the water level, the FILTER|CONTROL will decide when the next full cleaning is necessary.

- 3. Cover Sw. DF**

If the cover switch is defined as “Cover Sw. DF” where DF stands for drum filter, the backwashing will be stopped, if the cover is opened. Additionally, when the 230 V plug 2 is defined as “UVC lamp”, it will be also switched off immediately.

- 4. Cover Sw. EBF**

In case the cover switch is set to EBF, which means “Endlosbandfilter” or continuous belt filter, a backwashing will **not** be interrupted when the cover is opened. The UVC on 230 V plug 2 however will be switched off.

- **Water level**

All water level related parameters are system-specific. In this menu item, you can configure the cleaning-related water level settings.

- **Flush Level**

The flush level is the water level threshold, under (gravity system) or over (pumped system) which the cleaning is initiated. It is always displayed positive as a difference.

- **Dry run Protection**

The Dry run Protection level is the water level at which the circulation pump is deactivated and the system stopped. If the water level is below this level, the FILTER|CONTROL tries several times to reactivate the filter. Only if the operation can be safely continued, the FILTER|CONTROL goes back into the normal operation mode.

You will see this as a message in the display. The symbol “Pause” will also appear. To restart the operation manually, press “STOP”.

- **Backwash Parameter**

Here you can set all relevant parameters for the filter cleaning.

- **Backwash Duration**

The backwash duration defines the time of one cleaning cycle. Choose the flush time so that the drum is rotated at least one time completely.

- **Pre-flushing time**

With the pre-flushing time, you can define how long the spray pump is activated before the filter motor starts.

- **Post-flushing time**

To discharge also the last rest of particles from the flush tray, you can set with the post-flushing time the duration, how long the spray pump should stay activated after the filter motor stops.

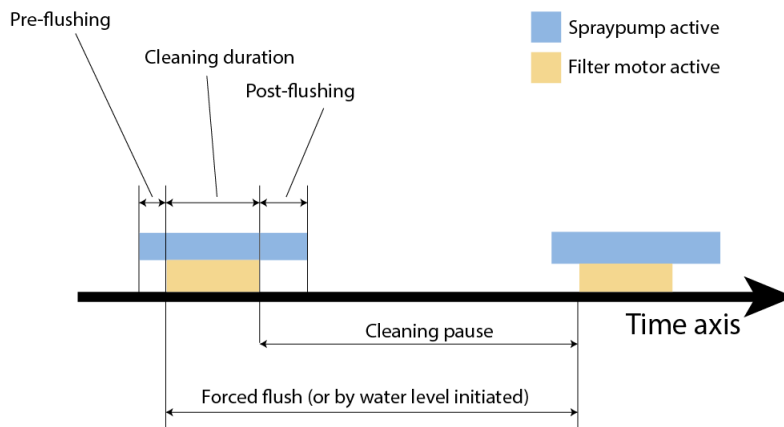

- **Cleaning pause**

The cleaning pause defines the minimal temporal distance between two filter cleaning events. This break prevents from water loss associated from too man cleaning events. But in case the water level drops further towards the emergency level, the filter flushes despite there is a cleaning pause. This function disables the cleaning pause in situations, when urgent cleaning is necessary.

- **Forced Clean. Cycle**

Here, you can specify how often the filter should be backwashed even when the sensor does not detect the necessity of backwashing. This means that you can set here the maximum time where the filer is not flushed.

---

- **Intensive cleaning**

Since the filter mesh can clog regularly by biofouling or calcareous crusts, the FILTER|CONTROL initiates in regular intervals an intensive cleaning mode where by a reduction of the motor speed the filter mesh is cleaned more intensively.

- **Interval**

The interval defines, how often the intensive cleaning programme should be run.

- **Duration**

With the duration, you can choose how long the intensive cleaning programme should activate the filter. The drum should be rotated at least one time full.

- **Motor speed**

To intensify the cleaning, the motor speed is reduced. Here you can choose the speed from 20% (slow) to 100% (max. speed).

- **Motor speed**

This menu item is the same as mentioned above, but valid for the normal flushing.

- **Eco-Mode**

With the Eco-Mode you can decrease the water consumption of your filter. When the water level sensor initiates the cleaning, only the filter motor is activated for a short time to bring the until then unused filter mesh into the water. By monitoring the water level, the FILTER|CONTROL will decide when the next full cleaning is necessary.

In this menu item, you can set how long every partial rotation of the drum should last.

- **Alarm**

The alarm mode specifies, when you will be alarmed. Several events can cause alarms:

- Dry run protection (can't be switched off)
- Forced Clean. Cycle (when the filter is backwashed, but the water level still decreases and the filter is forced to be cleaned again)
- Service interval (here you can select to be alarmed regularly e.g. when the filter has been backwashed 10.000 times. This function is intended to be a reminder for any maintenance work)

## Water Refill

If there is a SENECT solenoid valve connected to the FILTER|CONTROL, you can refill water on different ways.

- **Mode**

The „automatic water refill mode“ uses the measurements of the water level sensor in the tank, pond or pre-chamber. In the time-controlled mode, water is refilled based on your time settings in the timer table or by intervals.

You can also combine different types of the refill mode.

- **Operating time**

With the operating time you can define a time window during which the operation is active. For example you can allow the refill to be activated only during the day from 7:00 Uhr starting time until 19:00 Uhr stop time. Are both values set to 0:00, the operation is always set on active.

- **Auto. Water Refill**

As mentioned above, with the automatic refill mode, the water level sensor readings are used to regulate the water refill.

- **Refill level**

Here you can enter, under which water level the refill function should start its operation and open the solenoid valve. It stops, when the level 0 is reached again.

- **Max. Duration**

For limiting the water supply, you can define the maximum active duration of the automatic water refill.

- **Break time**

The break time allows you to set the minimum temporal distance between two refill events and represent another protection mechanism to prevent unwanted water refilling and can be helpful to recognize leakages.

- **Change zero-point**

To change the reference water level (0 cm), you can enter here a value which adjusts the reference level. E.g. if you want to fill your tank 2 cm higher, enter here + 2 cm.

- **Timer Table**

Besides the automatic mode, you can define certain times when water should be refilled.

Choose “+ New Entry” to create a new refill time. Enter the starting time and duration and press OK to save this entry.

By pressing ➔, you can delete entries from the list.

- **Interval mode**

With the interval function, you can define time intervals on which the refilling should be activated. Enter here the **duration** of each refill event, e.g. always refill for 5 minutes and the **interval** between the events, e.g. every 2 hours.

- **Man. Refill**

You can also refill just once water. Choose therefore Man. Refill and select the time, how long the refilling should be take place.

## Sensors

To change the settings, locations or types of the connected sensors, you can choose the items in this menu. Please do always pay attention to the manuals of each sensor.

- **Backwashing Sensor and Refill Sensor**

- **Sensor referencing**

Are all water levels in you system correct, you can set the sensor measurement to zero (0 cm). This is important since all regulation mechanisms like filter flushing or water refill use this zero point in their control function.

- **Alarm threshold**

In case there should be an alarm sent, when the sensor gives readings above or below a certain threshold, you can define these thresholds in this menu item. The hysteresis defines the tolerance of alarming. For example, if the lower threshold of -15 cm defines the alarm level and the water level fluctuates between -14.5 and -15.2 cm, the hysteresis of 1 cm eliminates several warnings always when the sensor reaches -15.0 cm.

In this menu item, you can also activate or deactivate the alarming of this sensor.

Please note, that the alarm is always referred to the **absolute** water level.

- **Sensor Type**

Select here the type of water level sensor you have connected. The water level probe PS has a range of 3.0 m (Type: PS-300-MA) while the EPS exhibits a range of 2.5 m (Type: EPS-250-MA).

- **Change zero-point**

If the sensor is used for refilling, you can change the zero-point (reference level) so that it is shiftet by the manually set level.

- **Cover switch**



Not every filter is equipped with a cover switch. That's why the cover switch can be deactivated in this menu item.

Please consider here that a cover switch is used for enhancing the security. If your filter is not equipped with a cover switch, never open the cover when the FILTER|CONTROL is operating!

## Menu output ports and 230 V AC plugs

With the FILTER|CONTROL you can select the function of the actuator outputs 1 to 3 (OUT 1 to 3 on the left side) and the main plug 2 (UVC / MOTOR on the bottom).

- **OUT 1**

- **Function**

Select here the function of the plug. You can choose between:

1. Filter Motor
2. Filter Pump
3. Circulation Pump
4. Sensor Control
5. Feeder
6. Time Control
7. Constant on
8. UVC Lamp
9. Alarm

Depending on the selected function, the menu changes dynamically and some of the following items may or may not appear.

- **Additional Function**

This function adds another function to the output port.

If you choose „**Alarm coupling**“, the output port responds to alarm signals as it is defined in the menu item **Alarm Handling**. The output can be switched on or off in case of an alarm.

By selecting „**Actor coupling**“ the output of the port can be switched in relation of another output. Choose in “actor coupling” the plug with which the output port should be connected

and the mode, how both should interact. You can choose between “Off”, “Off when on”, “Off when off”, “On when on” and “On when off”.

Additionally to the normal function, the extra function “**time-controlled**” can be added. It works analogous to the time-controlled function of the water refill where you can either enter specific times or define intervals.

- **Output signal**

The output signal can be configured in three different ways:

1. The **strength** of the signal: The output signal of OUT 1 and two are 0-24 V DC as pulse width modulation, 4 – 20 mA and 0 – 10 V DC signal (at OUT 3, only 0 – 24 V DC is available). With the strength you can set in % how strong the output signal is, e.g. 100% mean 24 V DC, 20 mA and 10 V, while 50% are 12 V DC, 12 mA and 5 V respectively).
2. **Start-up duration**: To increase and decrease the output signal slowly (ramp), the time of the start-up ramp can be set here. E.g. when you choose here 10 s, then the output strength will be linearly increased over 10 s to reach its maximum value (set by “Output strength”)
3. **Polarity**

The output polarity defines how the actor is activated. If the actor should be switched on by a voltage on the port, it is „active high“. This is the case for a normally closed solenoid valve for the water refilling. “Active low” would mean that if the output is activated, the voltage is reduced from 24 V to 0 V so that the actor can be activated (for example a normally opened solenoid valve).

- **Operating time**

The operating time is described in more detail in the water refill menu (page 22). Generally, it defines the active time window.

- **Description of the main output functions**

- **Filter Motor**

If the function „Filter motor“ is selected, the output is active when the filter motor is activated. By using output signals like 4-20 mA, you can for example also control variable frequency drives for using 380 V motors.

To control the motor speed via 4-20 mA and switching it on and off with 24 V DC, please select as “Additional function “ “Var. Frequency Drive”.

- **Spray Pump**

Defined as „Spray pump“, the output acts like the „**Spray pump**“ plug and is activated, as defined in the filter settings.

- **Circulation pump**

When defined as „circulation pump“, the output is switched on in normal mode, but will be switched off in case of alarming (e.g. water level below dry-run protection). Additionally, the circulation pump can be switched on and off with the STOP or PUMP button (break symbol in the display).

- **Sensor Control**

Is a second water level sensor connected to the SENSOR 2 port, extra functions can be added on OUT 2 depending on the sensor readings. It can for example be used for emptying a pump sump. By defining the “**Start-**” and “**Stop value**” you can set the thresholds of operation. Is the start value below the stop value, the output is active when the water level sinks below the start value. If it rises up to over the stop value, the output is deactivated. This can also be use vice-versa for example, when a pump sump should be emptied.

Like in the refill mode, you can also use protection parameters like “**Max. on time**” or “**break time**”.

- **Feeder**

Here you can choose the control of a fish feeder connected the output port. In the menu item “**Feeder**” you can choose if the port acts as the feeder itself or as an actuator which responds to the feeder (Skimmer Air Lift). If “Skimmer Air Lift” is selected, the output is activated 5 min before the feeder starts. With an air pump connected to this ouput, the skimmers can be lifted before feeding so that no swimming fish food can enter the filtration system directly.

If “feeder” is selected, the output behaves as the feeder which can be regulated by a time table or intervals.

- **Time control**

All settings for the time control work as described in the twer refill section.

- **Permanent on**

If the output should be continuously switched on, you have to select „permanent on“. You can also use the „Extra functions“ with this function.

- **UVC Lamp**

Is „UVC Lamp“ selected, the output behaves like in the mode „permanent on“ with the exeption that it is switched off, if the cover switch detects the opening of the filter cover.

Ensure that when a UVC lamp is operated in the filter, a cover switch protects the users from damage by viewing into the lightning lamp.



- **Alarm**

When the function „Alarm“ is selected, the output responds to alarm detections and activates the port. For example, the user can be warned visually by an alarm lamp (z.B. SENECT alarm lamp VIS-LED).

- **WLAN**
- **WLAN configuration**

If you want to integrate your FILTER|CONTROL in an existing WLAN-network, you need a Windows (Version 7 or higher), Android or iOS-based device on which the SENECT Control App is installed. The SENECT Control App is available in the Google Playstore or the Apple App Store. The Windows-version of the app can be downloaded on [www.senect.de/app](http://www.senect.de/app). 

Please have the name of the WLAN-network (SSID Name) and the WLAN-password ready.

You need to proceed through the following steps to **connect the FILTER|CONTROL to the internet:**

- Set the FILTER|CONTROL in WLAN configuration mode (Menu/WLAN/WLAN Configuration)
- Connect your smartphone or PC to the network SENECT\_AP (this is the FILTER|CONTROL)
- Start the SENECT Control App and press the button “WLAN Configuration”
- Enter the WLAN network name (SSID) and password. Set the security type and DNS (typically “WPA / WPA2” and “on”)
- Press “Einstellungen an Steuerung übertragen / Transfer settings to control unit”

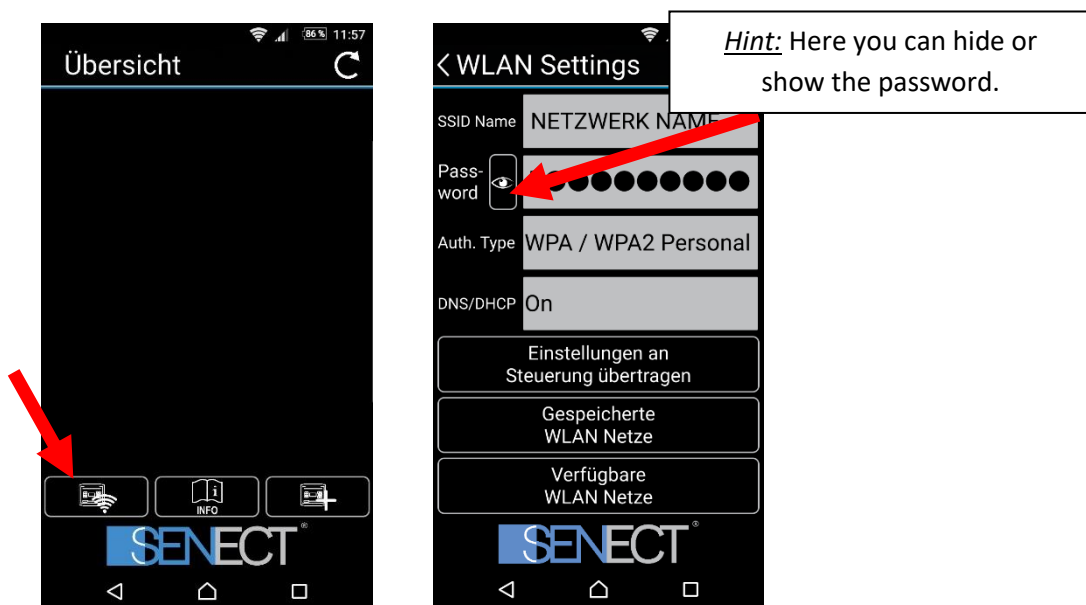

Now, the network information is transmitted from your smartphone to the FILTER|CONTROL which starts to establish the connection to your WLAN network. If this is successful, the WLAN symbol appears on the left side of the clock in the FILTER|CONTROL’s display.

Embedding the FILTER|CONTROL unit in your SENECT Control App:

1. Open the SENECT Control App and press the button “Add control unit”
2. Choose an individual name for the control unit and enter its IP Adress (you’ll find it under Menu/WLAN/Information).
3. Enter the corresponding dynamic DNS address (next chapter), port number (at delivery 30000) and PIN (at delivery 0000)
4. Press the button “Steuerung hinzufügen”



The FILTER|CONTROL can now be operated with your SENECT Control App when your smartphone / PC is within the same WLAN network. To **enable the remote access**, you need to establish a dynamic DNS connection:

1. Activate a DynDNS account (e.g. a MyFritz! account or register at dynDNS.org)
2. Open your internet router settings and allow the port forwarding
3. Send the dynamic DNS address to the control unit (via the app)

How this procedure works in detail, depends on the type of router. Here, we show this exemplarily for a **FRITZ!Box Router**:

1. Log in to your router (e.g. fritz.box)
2. Click on “Internet” to “Freigaben” and select to add a new device (“Gerät für Freigabe hinzufügen”)

The screenshot shows the FRITZ!Box 7490 web interface. The main heading is 'Internet > Freigaben'. Below this, there are tabs for 'Portfreigaben', 'FRITZ!Box-Dienste', 'DynDNS', and 'VPN'. The 'Portfreigaben' tab is active, showing a table of port forwarding rules. The table has columns for 'ID', 'IP-Adresse', 'Gerät', 'Port', 'Status', and 'Aktionen'. Below the table, there is a button 'Gerät für Freigabe hinzufügen' which is highlighted with a red arrow. Other buttons include 'Aktualisieren', 'Deaktivieren', 'Übernehmen', and 'Abbrechen'.

ID	IP-Adresse	Gerät	Port	Status	Aktionen
iwm-B6-6D-AA	192.168.178.99	Monitor 4 Aquarium	30003	<input type="checkbox"/> 0 aktiv	
iwm-B6-6D-B1	192.168.178.49	RAS Becken 5	30055	<input type="checkbox"/> 0 aktiv	
iwm-B6-7A-B5	192.168.178.56	RAS FC	30033	<input type="checkbox"/> 0 aktiv	
iwm-B6-7B-7F	192.168.178.61	RAS Mon 4	30067	<input type="checkbox"/> 0 aktiv	
iwm-B8-9A-94	192.168.178.58	RAS PRO	30044	<input type="checkbox"/> 0 aktiv	

3. Select at "Gerät" the FILTER|CONTROL. It will be labelled with "Senect-101xxxxx", where the x denote the serial number of your FILTER|CONTROL.

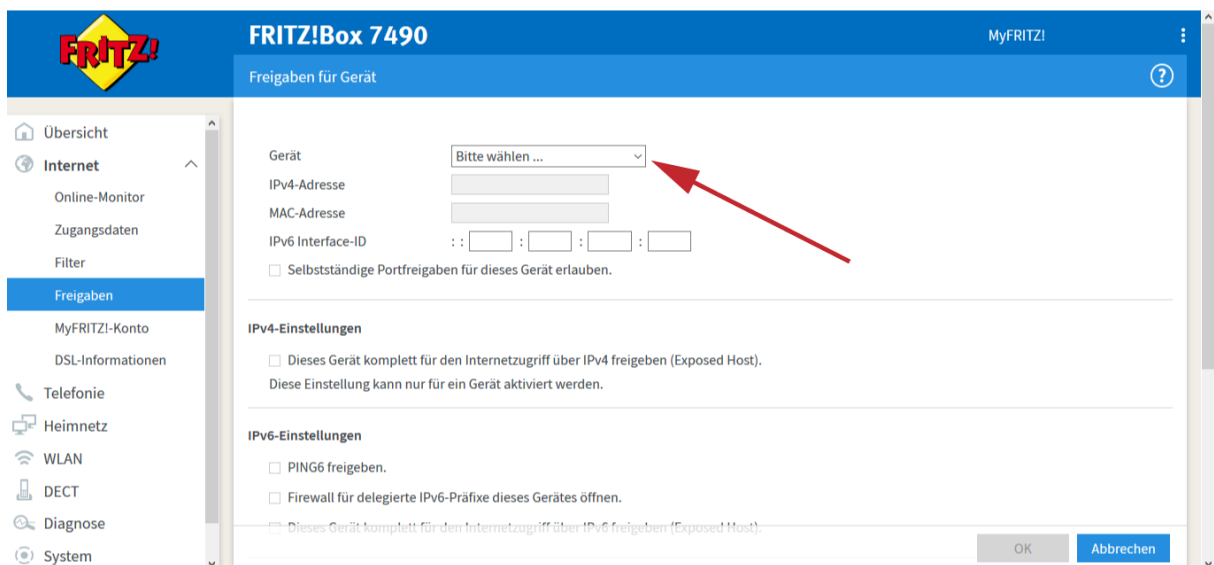

4. Click on "Neue Freigabe" and the Anwendung is "Andere Anwendung"

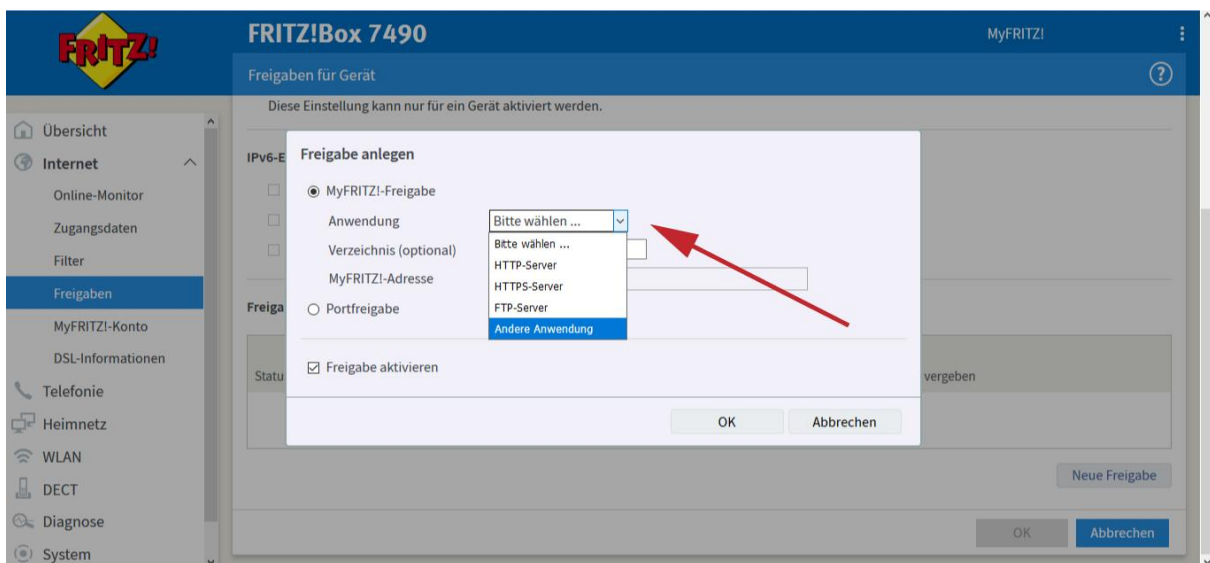

- Select as „Schema“: „http://“ and type in the port number of the FILTER|CONTROL (30000 as factory setting, if you use several SENECT control units, each single one must have its own port number. You can change it in the menu/WLAN/Port number)

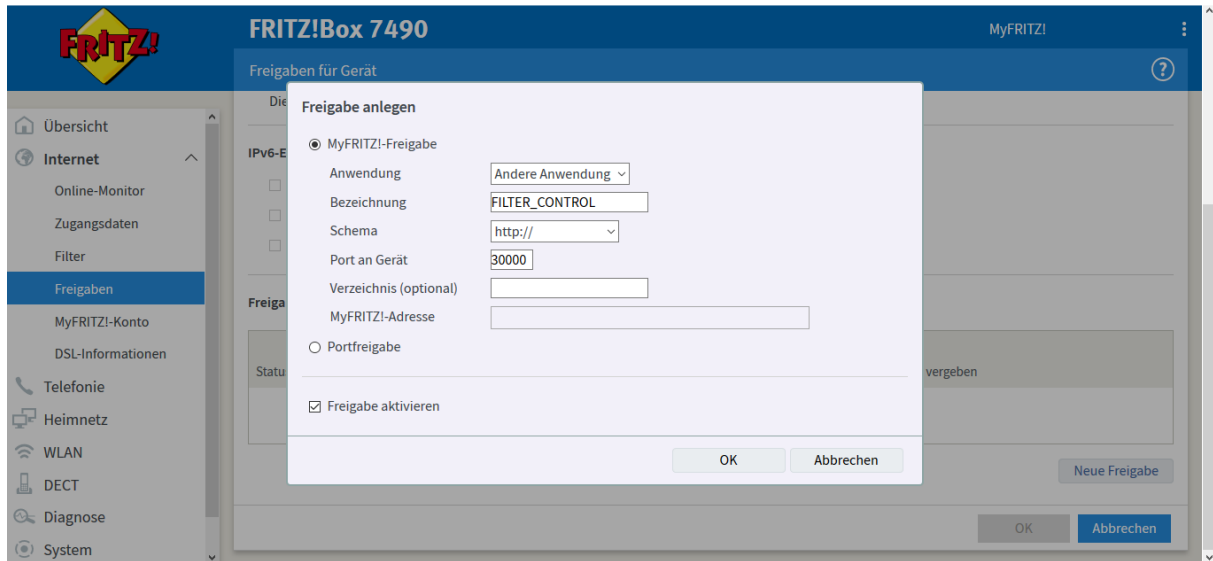

- Klick „OK“ to save your settings. The FILTER|CONTROL appears now in the overview and the status should turn to green (which may take some minutes).

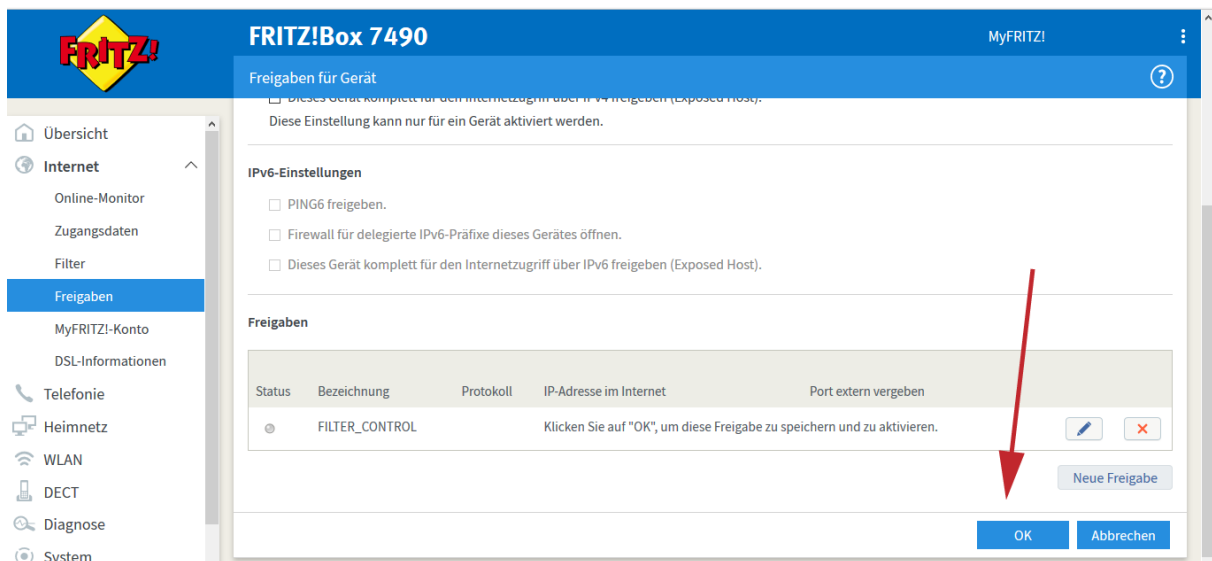

7. If you again click on the pen (Bearbeiten), a window will open where you can see the dynamic DNS address of the control unit. You need this address in the SENECT Control App to establish the remote access.

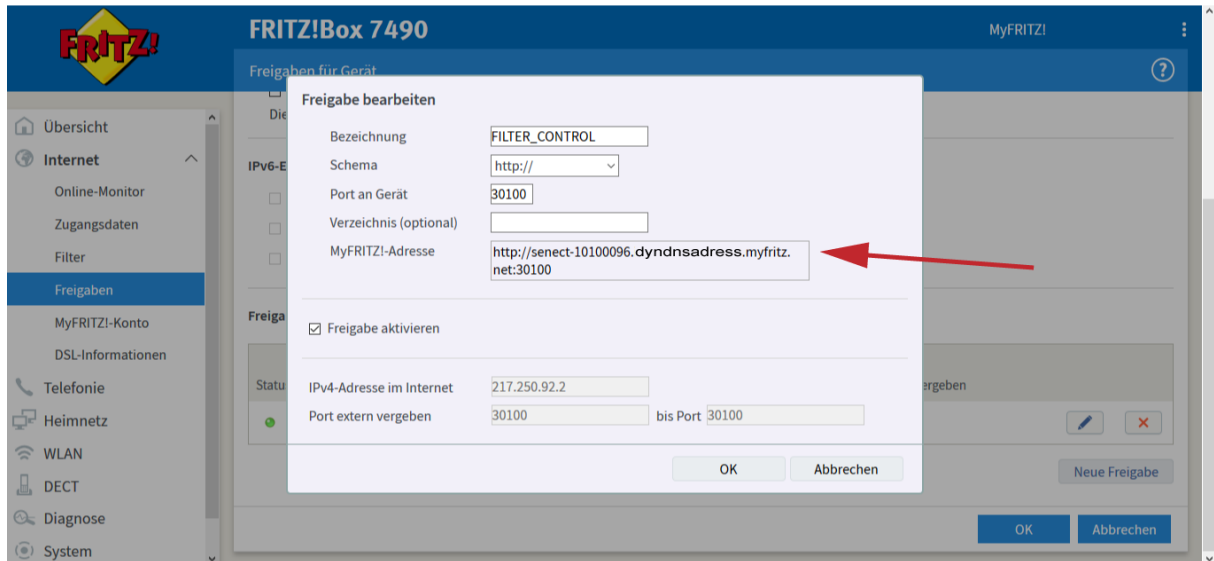

To enable the remote access with the SENECT Control App, you need to go to the WLAN settings of the control unit in your App. Press therefore the button “settings”.



Enter the dynamic DNS address without the “http://” and without the port number, e.g. here the “:30100” in the field Dyn DNS. Confirm with “Steuerung hinzufügen”.

Now, the remote access is enabled. You can test it, for example by switching off your WLAN in your smartphone (please ensure that you have then activated the use of mobile data”).

- **Start update**

If the update symbol appears in the display, a new update for your FILTER|CONTROL is available. Select „Start update“ to update your FILTER|CONTROL.

Do not switch the FILTER|CONTROL off during the update process!



- **WLAN Informations**

In this menu item you can see informations about the WLAN connection of the FILTER|CONTROL to your network.

- **System Settings**

- **Date & Time**

Set the date and time in this menu item. The FILTER|CONTROL is equipped with an internal rechargeable battery so that even without a power connection, the clock continues and all relevant settings are saved.

- **Language**

As language, „German“ and „English“ can be selected.

- **Factory settings**

If you want to reset the FILTER|CONTROL, choose „Factory settings“ and confirm with yes. Warning: All settings and saved parameters are deleted!

- **Pin Code**

Here you can enter a 4-number pin code to protect the FILTER|CONTROL from unauthorized usage. Note the pin code so that you unlock the FILTER|CONTROL again and store it at a safe place.

- **Device Infos**

Here you find information about the current device like the version of the firmware or the serial number of you FILTER|CONTROL.

## **Accessoires for the SENECT FILTER|CONTROL**

All listed accessories or accessory equipments are not in the scope of delivery of the FILTER|CONTROL. A detailed description of the accessory products can be found on our website [www.senect.de](http://www.senect.de).

Exemplarily, we present here some examples.

### **Connecting a solenoid valve to refill water**

To keep the water level in tanks or ponds constant and operate the system under optimal hydraulic conditions, the FILTER|CONTROL in combination with a water level probe (PS-300-MA) and a solenoid valve (MVW-M12-SC) can be used. Connect therefore the sensor at SENSOR 2 and the solenoid valve at OUT 2.

## **Troubleshooting: What if...**

### **...the display says „Cover switch opened“**

Then either the cover is really opened or the cable of the cover switch is not connected. If there is no cover switch installed in your filter, you can disable the cover switch function in the menu (Sensors / cover switch).

**... the measurement values of the water level probe fluctuate:**

In this case the water level probe is often placed in a location with high currents and measures the impact of the flow. Please relocate the probe to a place with only minor currents.

**...there are long-term changes in the values of the water level probe:**

Is the water level changing by 5 to 15 cm over days additionally to the short term changes induced by the filter clogging, then it is likely that the capillary cable of the probe is damaged or the filter (e.g. on the plug) is blocked. Then the pressure exchange with the atmosphere is blocked and the atmospheric pressure is added to the hydrostatic pressure (water level induced pressure). Check therefore the cable and plug.

## Technical Data

Dimensions	260 x 228 x 127 mm
Cable length (power)	2,8 m
Voltage	230 V AC / 50 Hz
Output power 24 V DC	Total max. 120 W (FC-A1-333-150) or 280 W (FC-A1-333-300)
Output power 230 V AC	Spraypump max. 1800 W UVC / Motor max. 450 W Circulation pump max. 900 W
Power consumption*	< 8 W (FC-A1-333-150) < 18 W (FC-A1-333-300)
Temperature range	0°C to +45°C
Ingress protection	IP 54, if no 230 V plugs are connected.

\*The power consumption is defined as the power of the FILTER|CONTROL without connected consumers.

## Information about the correct disposal



Your device is well packed at delivery. Please dispose the packaging material accordingly to the regulations in your country.

Do not throw the product in the casual litter bin. Make sure you are informed about the local disposal regulations and dispose your product accordingly. Alternatively, you can also send the product back to the producer.

The SENECT GmbH & Co. KG is member of the Stiftung Elektro-Altgeräte Register and the products are registered (WEEE-Reg.-Nr.: DE37193510).

## Guarantee



Please check at delivery of your FILTER|CONTROL, that all parts are delivered completely and that they function correctly. In case of any claims, contact us immediately per email or phone ([info@senect.de](mailto:info@senect.de) or +49-6341 - 95 95 210). Please describe your claim as detailed as possible so that we can provide a solution as fast as possible. The following details must be given to guarantee a fast support:

- Detailed error or claim description
- Information about the use of the FILTER|CONTROL (e.g. system type, filter)
- Your contact information

The FILTER|CONTROL has a guarantee of 1 year and a warranty of 2 years. Furthermore, the § 377 HBG (German law) is valid.